

HeatPak

Installation, Commissioning, User & Maintenance Instructions

Models:

H 20 06	H 30 06	H 40 06
H 20 10	H 30 10	H 40 10
H 20 20	H 30 20	H 40 20

HP 20 06	HP 30 06	HP 40 06
HP 20 10	HP 30 10	HP 40 10
HP 20 20	HP 30 20	HP 40 20

LV311286 | June 2014





IMPORTANT INFORMATION

These instructions must be read and understood before installing, commissioning, operating or maintaining the equipment.



Read this manual carefully**Warning**

Read this manual carefully before starting the HeatPak module. Failure to read the manual and to follow the printed instructions may lead to personal injury and damage to the HeatPak-module and water heater.

Copyright © 2013

All rights reserved.

Nothing from this publication may be copied, reproduced and/or published by means of printing, photocopying or by whatever means, without the prior written approval of the supplier.

The supplier reserves the right to modify specifications stated in this manual.

Trademarks

Any brand names mentioned in this manual are registered trademarks of their respective owners.

Liability

The supplier accepts no liability for claims from third parties arising from unauthorised use, use other than that stated in this manual, and use other than in accordance with the General Conditions registered at the Chamber of Commerce.

Refer further to the General Conditions. These are available on request, free of charge.

Although considerable care has been taken to ensure a correct and suitably comprehensive description of all relevant components, the manual may nonetheless contain errors and inaccuracies.

Should you detect any errors or inaccuracies in the manual, we would be grateful if you would inform us. This helps us to further improve our documentation.

More information

If you have any comments or queries concerning specific aspects related to HeatPak, then please do not hesitate to contact :

Lochinvar Ltd.
7 Lombard Way
The MXL Centre
Banbury
Oxon
OX16 4TJ

Tel: +44 (0) 1295 269 981
Fax: +44 (0) 1295 271 640
E-mail: info@lochinvar.ltd.uk
Website: www.lochinvar.ltd.uk

In the event of problems with your electricity or water supply connections, please contact the supplier/installation engineer of your installation.

Content

1	Introduction	7
	1.1 About HeatPak	7
	1.2 Regulations	7
	1.3 Target groups	7
	1.4 Maintenance	7
	1.5 Overview of this document	8
2	Working principal	10
	2.1 Introduction	10
	2.2 General working principle of HeatPak	10
	2.3 Heating cycle	10
	2.4 Control of the HeatPak module	11
	2.5 Safety of the HeatPak module	12
3	Installation	15
	3.1 Introduction	15
	3.2 Packaging	15
	3.3 Ambient conditions	15
	3.4 Installation diagram	16
	3.5 Water connections	18
	3.6 Electrical connections	19
4	Filling	25
	4.1 HeatPak system	25
	4.2 Heating system	25
5	Draining	27
	5.1 HeatPak system	27
	5.2 Heating system	27
6	Starting	29
	6.1 Introduction	29
	6.2 Set heating functionality	29
	6.3 Set heating setpoint.....	30
	6.4 Set priority protocol	30
7	Shutting down	31
	7.1 Introduction	31
	7.2 Decommissioning for a short period	31
	7.3 Decommissioning for a long period	32
8	Errors	33
	8.1 Introduction	33
	8.2 Troubleshooting table for general errors	34
	8.3 Troubleshooting table for displayed errors	35
9	Performing maintenance	39

10	Warranty	41
10.1	General warranty	41
10.2	Conditions for installation and use	41
10.3	Exclusions	41
10.4	Scope of the warranty	42
10.5	Claims	42
10.6	Obligations of Lochinvar Ltd	42
11	Appendices	43
11.1	Introduction	43
11.2	Electrical diagram HeatPak module	44
11.3	Configuration 3-way mixing valve	46

1 Introduction

1.1 About HeatPak

This manual describes how to install, use and service the different types of HeatPak modules. These modules can be connected to a EcoCharger (ECH) and a EcoCharger Hybrid (HWHC and HWH), so these water heaters can also be integrated into a (central) heating system.

The information in this manual applies to the Heat Pak modules: H (for the HWHC and HWH) and HP (for the ECH).

1.2 Regulations

Warning

The installation must be carried out by an approved installation engineer in compliance with the general and local regulations imposed by the gas, water and power supply companies and the fire brigade.

The boiler room must be frost-free, or be protected against frost. The ambient conditions, as shown in paragraph 3.3, should be adhered in order to ensure the functionality of the used electronics.

1.3 Target groups

The three target groups for this manual are:

- (end)users;
- Installation engineers;
- service and maintenance engineers.

In paragraph [1.5 "Overview of this document"](#) indicates which chapter is applicable to the relevant target groups.

1.4 Maintenance

Caution

The HeatPak modules are not intended for use by persons with reduced physical, sensory or mental capacities, or who lack the necessary experience or knowledge, unless the person responsible for their safety is supervising them or has explained to them how the modules should be used.

Caution

The HeatPak modules are not intended to be used by children. Always supervise children, and ensure that they do not play with these modules water heater.

Service should be carried out at least once a year, both on the water side and on the electrical side. Among other things, the service interval depends on the amount of burner hours and set water temperature.

Note

To determine the correct service interval, it is recommended to arrange for the service and maintenance engineer to check the water heater on both the water and gas side within three months following installation. Based on this check, the best service interval can be determined.

Note

Regular maintenance extends the device life of the parts.

Both the end user and the service and maintenance engineer are responsible for regular maintenance. They will need to establish clear agreements on this.

1.5 Overview of this document

The table provides an overview of the contents of this document.

Contents of this document

Chapter	Target groups	Description
<u>Working principle</u>	<ul style="list-style-type: none"> • (end)user • Installation engineers • service and maintenance engineers 	This chapter describes the working principle of the HeatPak modules.
<u>Installation</u>	<ul style="list-style-type: none"> • Installation engineers • service and maintenance engineers 	This chapter describes the installation activity to be completed before you start for the first time.
<u>Filling</u>	<ul style="list-style-type: none"> • (end)user • Installation engineers • service and maintenance engineers 	This chapter describes how to fill the system.
<u>Draining</u>	<ul style="list-style-type: none"> • (end)user • Installation engineers • service and maintenance engineers 	This chapter describes how to drain the system.
<u>Starting</u>	<ul style="list-style-type: none"> • (end)user • Installation engineers • service and maintenance engineers 	This chapter describes how to take HeatPak into operation.
<u>Shutting down</u>	<ul style="list-style-type: none"> • (end)user • Installation engineers • service and maintenance engineers 	This chapter describes how to take the HeatPak system out of operation.
<u>Failures</u>	<ul style="list-style-type: none"> • (end)user • Installation engineers • service and maintenance engineers 	This chapter is mainly intended for the installation engineer and the service and maintenance engineer. It describes the HeatPak errors.
<u>Maintenance</u>	<ul style="list-style-type: none"> • service and maintenance engineers 	This chapter sets out the maintenance tasks to be carried out.
<u>Warranty</u>	<ul style="list-style-type: none"> • (end)user • Installation engineers • service and maintenance engineers 	This chapter states the warranty terms and conditions.

2 Working principal

2.1 Introduction

This chapter covers the following topics:

- General working principle of the HeatPak modules;
- Heating cycle;
- Safety of the HeatPak modules.

2.2 General working principle of the HeatPak module

HeatPak is a module that connects a Domestic Water system (DHW system) and a heating system. By using a HeatPak module, heat from a water heater (ECH, HWHC or HWH) can be transferred, through a plate heat exchanger, to the heating system.

Through the use of an intelligent control there is an optimal use of the available hot water supply. Without compromising on comfort the system can provide hot water demand from both domestic hot water system and heating system.

The intelligent control controls the domestic hot water and heating system through a number of sensors and directs the DHW-pump and 3-way mixing valve in order to achieve the desired flow temperature on the heating side of the system.

Note

The maximum working pressure, on the DHW-side of the system, is 8 bar. The minimum working pressure, on the heating-side of the system, is 1 bar and the maximum working pressure is 3 bar.

2.3 Heating cycle

At heat demand on the heating side of the system, from the room thermostat, the DHW-pump (modulating) and a heating pump will be activated by the controller. To reach the desired supply temperature the 3-way mixing valve will also be activated.

In the 3-way mixing valve, the water that runs through the plate heat exchanger is mixed with hot water from the water heater, in order to transfer enough heat in the plate heat exchanger, which will result in the desired supply temperature of the heating water. The desired heating supply temperature (heating setpoint) can be set on the controller of the water heater.

The desired temperature depends on the type of heating system. The heating supply temperature is measured by temperature sensor S_5 which is mounted on heating supply pipe.

Note

Temperature sensor S_5 has a control function and is not to be used as a safety for the heating system. This kind of safety should be regulated separately and is the full responsibility of the installer.

Note

The pressure protection must also be provided separately and is the full responsibility of the installer.

2.4 Control of the HeatPak module

2.4.1 Introduction

The HeatPak module, consists out of various components which provide the warming of the heating water, such as:

- the controller;
- the 3-way mixing valve;
- the DHW pump;
- the heating pump;
- the temperature sensor;
- the room thermostat.

2.4.2 Controller

The controller of the HeatPak module (Heat Master for ECH and Solar Heat Haster for the HWHC and HWH) is the device that uses various temperature sensors and a room thermostat to control various elements (3-way mixing valve, DHW-pump and heating pump) of the HeatPak module.

In addition to the control of various components, the controller has a number of other functions, such as:

- protection of the DHW-pump and heating pump against seizing due to prolonged arrest;
- monitoring the temperature of the heating system ([2.5.3 "Temperature monitoring of heating system"](#));
- prevention against legionella ([2.5.4 "Legionelle prevention"](#));
- DHW detection for simultaneity ([6.4 "Simultaneity"](#)).

Example of HeatPak installation in combination with a EcoCharger

Legend

1. control
2. 3-way mixing valve
3. temperature sensor S_5
4. plate heat exchanger
5. heating pump
6. room thermostat
7. DHW-pump
8. stop valve
9. (manual) air vent

- A cold water supply
 B hot water supply
 C heating supply pipe
 D heating return pipe

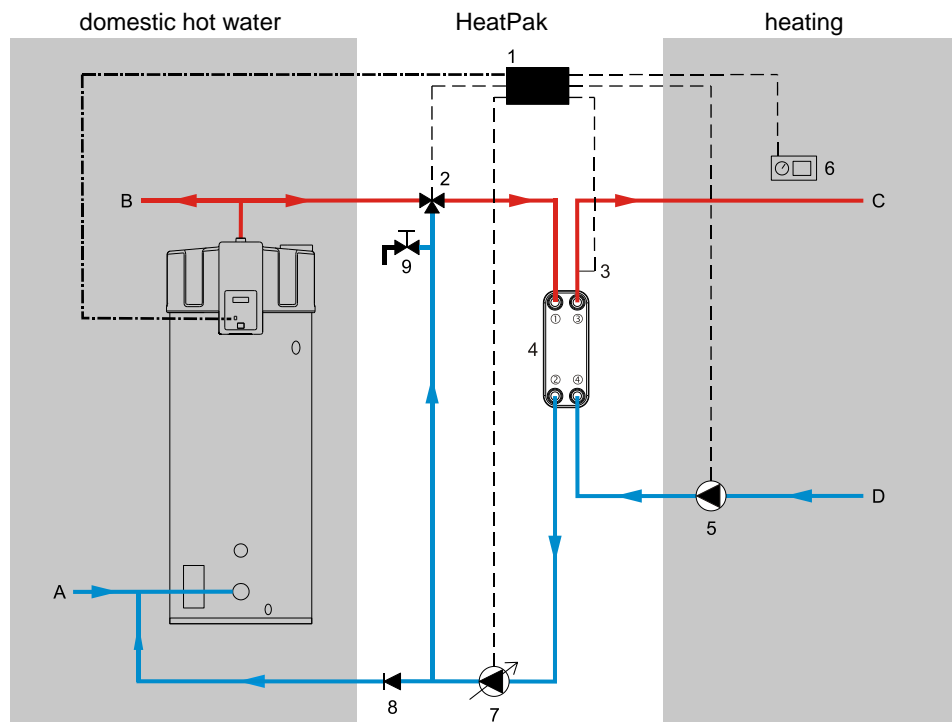

IMD-1123b R0

2.4.3 3-way mixing valve

The control opens and closes the 3-way mixing valve in order to control the flow of (hot) water through the plate heat exchanger. With this (hot) water the water in the heating system is heated.

Note

The supplied 3-way mixing valve does not need to be adjusted. This valve is set at the factory and must be installed according to the installation diagram in paragraph 3.4. The configuration of the 3-way mixing valve can be checked according to the instruction in paragraph 11.5. When an alternative way of connection is desired, please contact Lochinvar Ltd..

2.4.4 DHW pump

The controller controls the DHW pump. The DHW-pump is mounted in the DHW-side of the HeatPak system. The modulating controlled pump ensures sufficient flow of (hot) water through the plate heat exchanger on the DHW-side of the plate heat exchanger.

2.4.5 Heating pump

The controller controls the heating pump. The heating-pump is mounted in the heating side of the HeatPak system. The ON/OFF-pump ensures the flow of (hot) heating water through the plate heat exchanger on the heating side of the plate heat exchanger.

Note

The heating pump is not part of the HeatPak module and is thus not included with the HeatPak module, because its size depends on the corresponding heating system.

2.4.6 Temperature sensor

The controller measures with temperature sensor S₅ the temperature of the heating water in the heating supply pipe. This sensor is mounted, directly after the plate heat exchanger, on the heating supply pipe.

2.4.7 Room thermostat

The controller controls the desired room temperature. Depending on the desired temperature the controller controls the 3-way mixing valve, DHW-pump and/or heating pump to reach the desired room temperature.

Important

Two different types of thermostats can be connected to the HeatPak module. To the controller a 24 V ON/OFF- or 230 V Switched Live Thermostat (SWL-thermostat) can be connected. An OpenTherm or other thermostat does not work in combination with the HeatPak module.

2.5 Safety of the HeatPak module

2.5.1 Introduction

The controller, of the HeatPak module, also has other functions besides the control of various components, such as:

- protection, of both pumps, against seizing;
- monitoring of temperature of the heating water;
- protection against legionella;
- DHW detection of simultaneity (6.4 "Setting priority rule").

2.5.2 Protection of both pumps

The controller protects both pumps (DHW-pump and heating pump) against jamming due to prolonged stand still. When the pumps are not activated within 24 hours, by heat demand, the controller will activate the pumps for a short period of time.

2.5.3 Monitoring heating water temperature

The controller monitors the temperature of the heating water with temperature sensor S₅. This sensor is mounted on the heating supply pipe, with the supplied clip. This sensor must be mounted, as close as possible to the plate heat exchanger, on the heating supply pipe.

Temperature protection

Safety	Description
<u>Against frost:</u> S ₅ < 5°C	The frost protection cuts in when the temperature of the heating water, in the heating supply pipe (measured with temperatures sensor S ₅), is less the 5°C. The DHW-pump and heating pump are activated by the controller. The heating water, in the heating supply pipe, is heated to 30°C.
<u>Against overheating of water:</u> S ₅ > heating set point + 20K	The overheat protection cuts in when the temperature of the heating water, in the heating supply pipe, exceeds the heating set point (6.4 "Heating set point") by 20°C. The controller will de-activate the DHW-pump. In the event that this protection is activated 3 times, there will be a blocking error on the display of the water heater and the heating system will be switched off. This error will disappear when the temperature of the heating water, in the heating supply pipe, is below the heating set point (S ₅ < heating set point). See error F20 (8.3 "Troubleshooting table for displayed errors").

Note

The frost protections protects only the HeatPak module and not the heating system (pipes, radiators, etc.).

Important

The frost protection of the heating system (pipes, radiators, etc.) falls under the responsibility of the user and/or installer.

2.5.4 Legionella prevention

Legionella prevention is set in the controller of the water heater (see "Setting legionella prevention" in the Installation, Commissioning, User & Maintenance Instructions of the water heater). When the legionella prevention is switched on, the DHW-pump and the 3-way mixing valve in the HeatPak system, will be activated via the HeatPak module.

When the legionella prevention is activated, the following display will be activated.

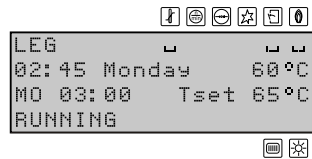

The image shows a control panel display with a grey background and black text. At the top, there are six small icons: a square with a vertical line, a square with a circle, a square with a triangle, a square with a cross, a square with a circle, and a square with a vertical line. Below the icons, the text reads: "LEG", "02:45 Monday 60°C", "MO 03:00 Tset 65°C", and "RUNNING". At the bottom right, there are two small icons: a square with a circle and a square with a cross.

3 Installation

Warning

The installation must be carried out by an approved installation engineer in compliance with the general and local regulations imposed by the gas, water and power supply companies and the fire brigade.

The HeatPak modules may only be installed in a room that complies with the requirements stated in national and local ventilation regulations ([1.3 "Regulations"](#)).

3.1 Introduction

This chapter describes the installation activities to be carried out before the HeatPak module can be installed, namely:

- Packaging;
- Ambient conditions;
- Connection diagram;
- Water connections;
- Electrical connections.

3.2 Packaging

The parts, for installation, are supplied in one packaging unit. Remove the packaging carefully to avoid damaging the parts.

The module consists of the following parts:

- Plate heat exchanger (excl. insulation package);
- DHW pump (excl. cable);
- Temperature sensor (incl. cable and clamp);
- 3-way mixing valve (incl. cable);
- 2 Reducing nipples (G1" to 22 mm press) for the DHW-pump;
- 3 Reducing nipples (Rp 3/4" to 22 mm press) for the 3-way mixing valve;
- Controller;
- Communication cable (between controller of the water heater and the controller of the HeatPak module, only ECH).

3.3 Ambient conditions

The boiler room must be frost-free, or be protected against frost. The table shows the ambient conditions that must be adhered to for correct functioning of the electronics present in the module to be guaranteed.

Air humidity and ambient temperature specifications

Air humidity and ambient temperature	
Air humidity	Max. 93% RH at +25°C
Ambient temperature	Functionality $0 \leq T \leq 60^{\circ}\text{C}$

3.4 Installation diagram The figures show the Installation diagram. This diagram is referred to in the sections describing the actual connection procedure.

Installation diagram: HeatPak with a ECH - Vented.

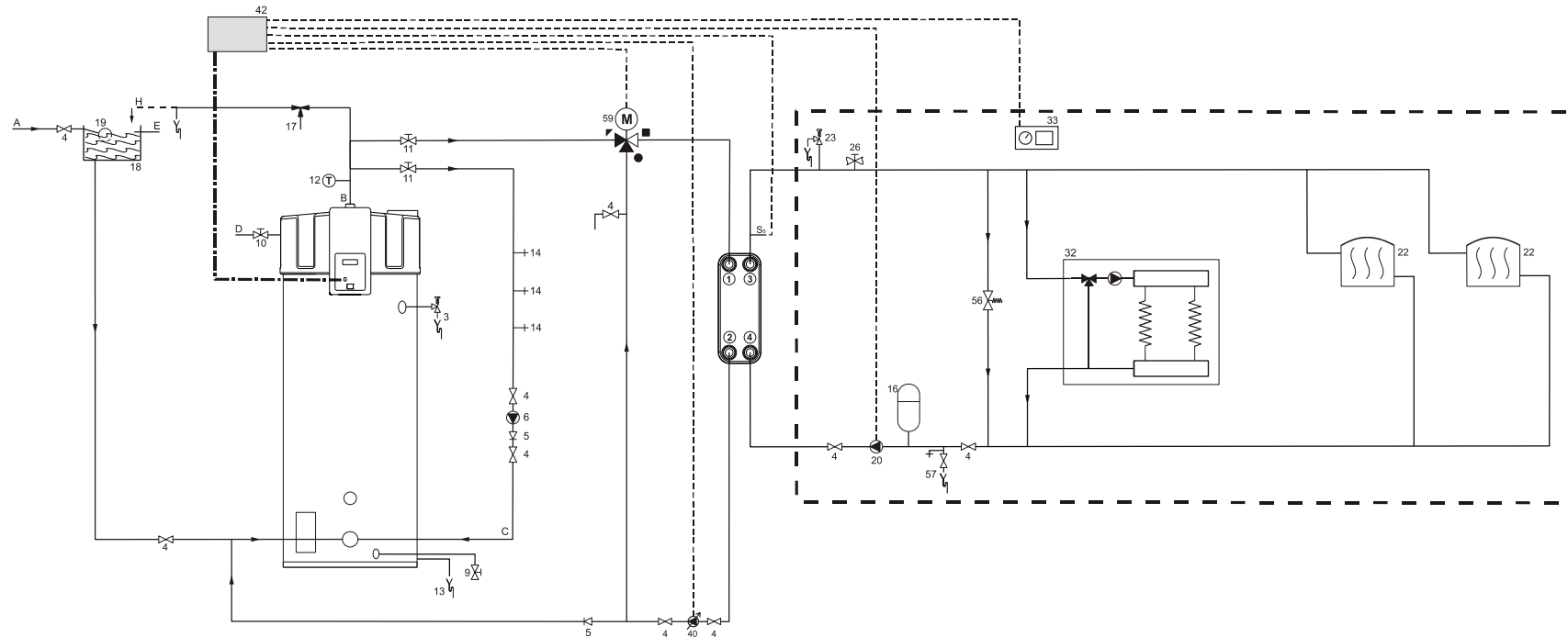

Legend

- | | | | |
|--|--|------------------------------------|--|
| 3. T&P valve (mandatory) | 18. cold water head tank | 59. 3-way mixing valve (mandatory) | ▶ hot water supply 3-way mixing valve from water heater |
| 4. stop valve (recommended) | 19. float switch | A. cold water supply | ■ outlet 3-way mixing valve to plate heat exchanger |
| 5. non-return valve (mandatory) | 20. heating pump (mandatory) | B. hot water supply | ● return water to 3-way mixing valve from plate heat exchanger |
| 6. circulation pump (optional) | 22. radiator | C. circulation pipe | |
| 9. drain valve | 23. pressure valve (mandatory) | D. gas supply | S ₅ heating system sensor |
| 10. manual gas valve (mandatory) | 26. heating filling tap (recommended) | E. overflow pipe | |
| 11. service stop valve (recommended) | 32. floor heating | F. supply heat exchanger | |
| 12. temperature gauge (optional) | 33. room thermostat | G. heat exchanger return | |
| 13. condensation drain | 40. DHW-pump | H. overflow protection | |
| 14. draw-off point | 42. control HeatPak module | | |
| 16. expansion vessel (mandatory) | 56. pressure valve (recommended) | | |
| 17. 3-way aeration valve (recommended) | 57. filling and draining valve (mandatory) | | |

IMD-1156b R0.0

Installation diagram: HeatPak with a ECH - Unvented.

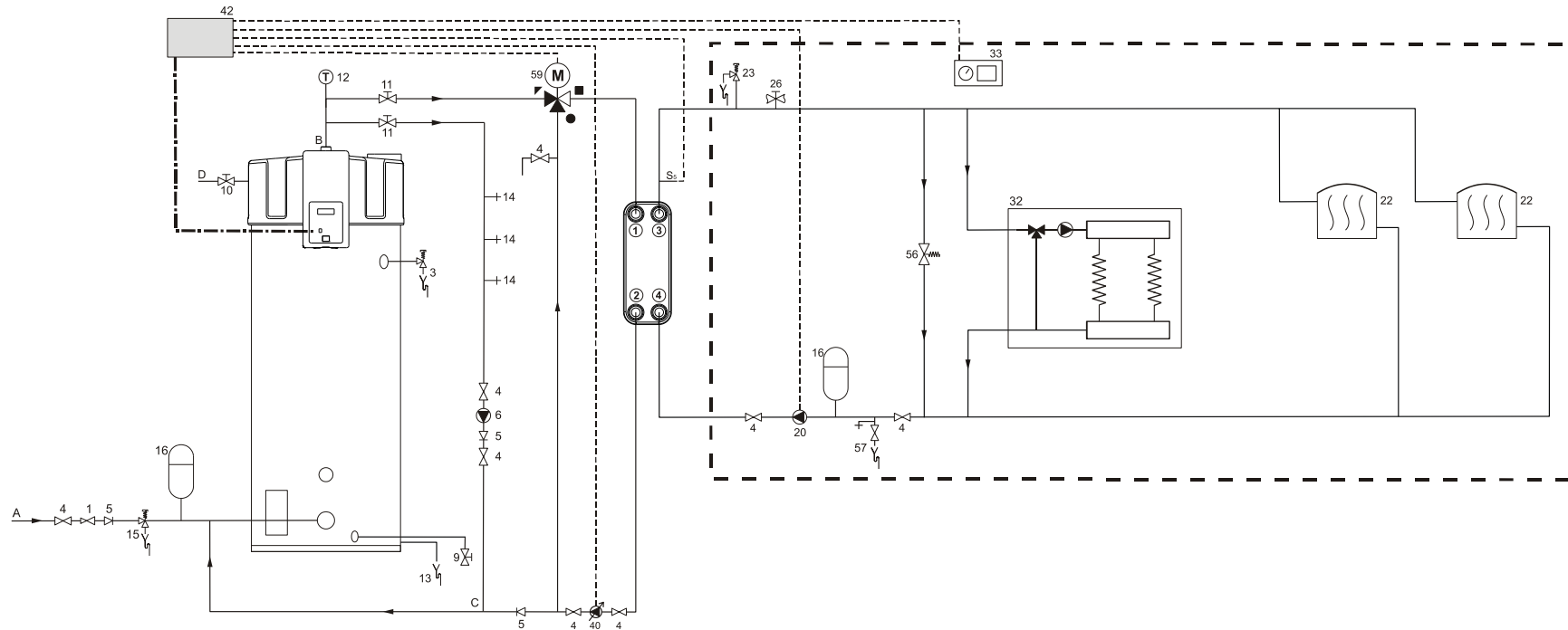

IMD-1157b R0.0

Legend

- | | | | |
|--|--|----------------------|--|
| 1. pressure relief valve (mandatory if the mains water pressure is too high) | 20. heating pump (mandatory) | A. cold water supply | ▀ hot water supply 3-way mixing valve from water heater |
| 3. T&P valve (mandatory) | 22. radiator | B. hot water supply | ■ outlet 3-way mixing valve to plate heat exchanger |
| 4. stop valve (recommended) | 23. pressure valve (mandatory) | C. circulation pipe | ● return water to 3-way mixing valve from plate heat exchanger |
| 5. non-return valve (mandatory) | 26. heating filling tap (recommended) | | |
| 6. circulation pump (optional) | 32. floor heating | | |
| 9. drain valve | 33. room thermostat | | |
| 10. manual gas valve (mandatory) | 40. DHW-pump | | |
| 11. service stop valve (recommended) | 42. control HeatPak module | | |
| 12. temperature gauge (optional) | 56. pressure valve (recommended) | | |
| 13. condensation drain | 57. filling and draining valve (mandatory) | | |
| 14. draw-off point | 59. 3-way mixing valve (mandatory) | | |
| 15. expansion valve (mandatory) | | | |
| 16. expansion vessel (mandatory) | | | |
| | | | S ₅ heating system sensor |

Installation diagram: HeatPak with a HWHC - Vented.

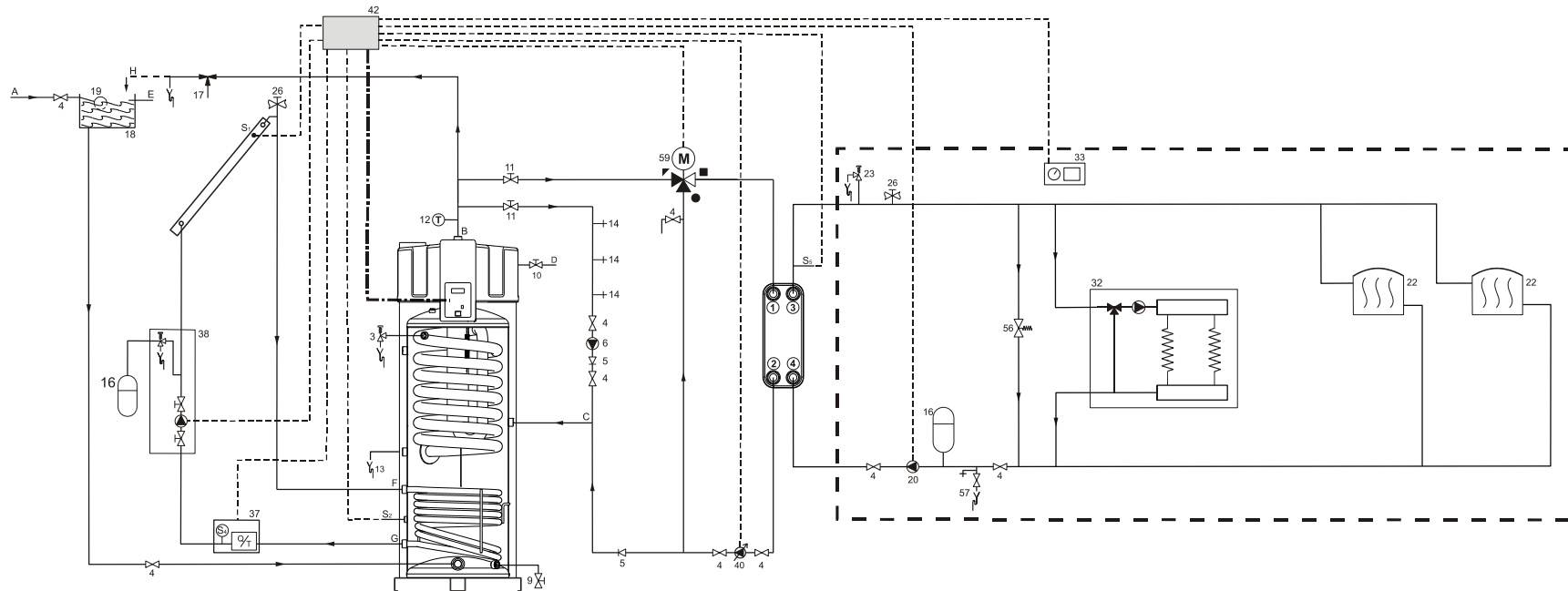

IMD-1165b R0.0

Legend

- | | | | |
|--|--|--------------------------|--|
| 3. T&P valve (mandatory) | 22. radiator | A. cold water supply | ▀ hot water supply 3-way mixing valve from water heater |
| 4. stop valve (recommended) | 23. pressure valve (mandatory) | B. hot water supply | ■ outlet 3-way mixing valve to plate heat exchanger |
| 5. non-return valve (mandatory) | 26. heating filling tap (recommended) | C. circulation pipe | ● return water to 3-way mixing valve from plate heat exchanger |
| 6. circulation pump (optional) | 32. floor heating | D. gas supply | |
| 9. drain valve | 33. room thermostat | E. overflow pipe | |
| 10. manual gas valve (mandatory) | 40. DHW-pump | F. supply heat exchanger | |
| 11. service stop valve (recommended) | 42. control HeatPak module | G. heat exchanger return | |
| 12. temperature gauge (optional) | 56. pressure valve (recommended) | H. overflow protection | |
| 13. condensation drain | 57. filling and draining valve (mandatory) | | |
| 14. draw-off point | 59. 3-way mixing valve (mandatory) | | |
| 17. expansion vessel (mandatory) | | | |
| 17. 3-way aeration valve (recommended) | | | |
| 18. cold water head tank | | | |
| 19. float switch | | | |
| 20. heating pump (mandatory) | | | |
| | | | S ₁ collector sensor |
| | | | S ₂ tank sensor |
| | | | S ₄ solar heating system return sensor (optional) |
| | | | S ₅ heating system sensor |

Installation diagram: HeatPak with a HWHC - Unvented.

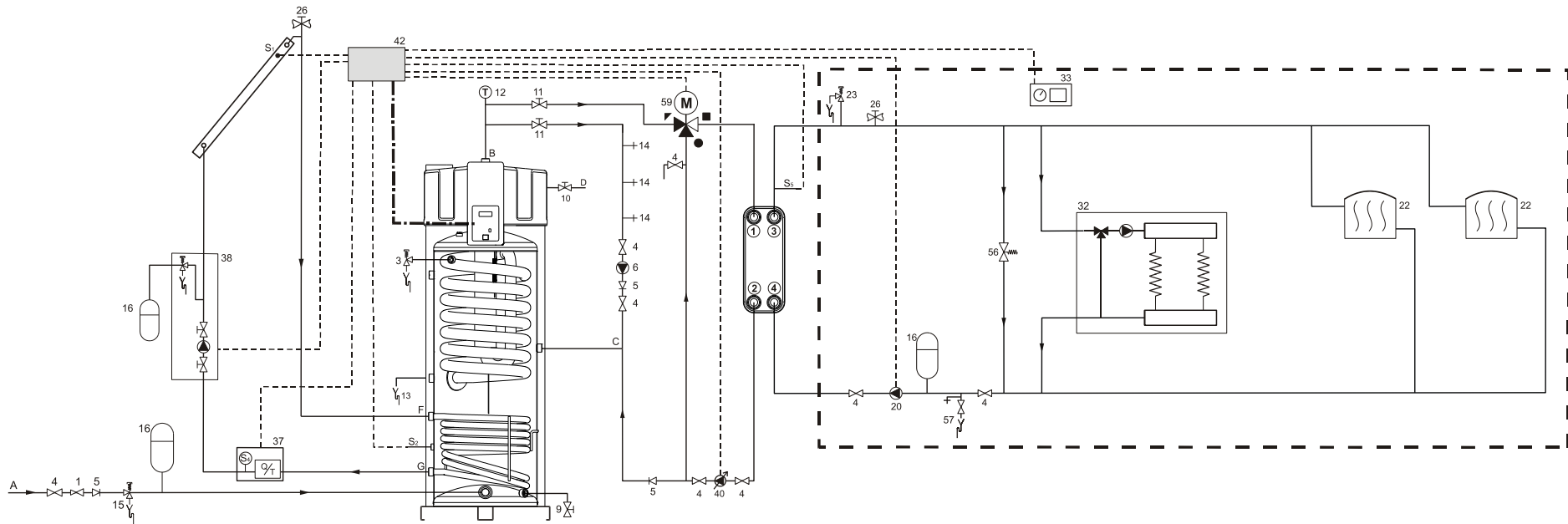

IMD-1166b R0.0

Legend

- | | | | |
|--|---|---|--|
| 1. pressure relief valve (mandatory if the mains water pressure is too high) | 26. heating filling tap (recommended) | C. circulation pipe | ● return water to 3-way mixing valve from plate heat exchanger |
| 3. T&P valve (mandatory) | 32. floor heating | D. gas supply | |
| 4. stop valve (recommended) | 33. room thermostat | F. supply heat exchanger | |
| 5. non-return valve (mandatory) | 37. combined Q/T sensor (optional) | G. heat exchanger return | |
| 6. circulation pump (optional) | 38. solar heating pump station (modulating - mandatory) | | S ₁ collector sensor |
| 9. drain valve | 40. DHW-pump | | S ₂ tank sensor |
| 10. manual gas valve (mandatory) | 42. control solar heating system | | S ₄ solar heating system return sensor (optional) |
| 11. service stop valve (recommended) | 56. pressure valve (recommended) | | S ₅ heating system sensor |
| 12. temperature gauge (optional) | 57. filling and draining valve (mandatory) | | |
| 13. condensation drain | 59. 3-way mixing valve (mandatory) | | |
| 14. draw-off point | | | |
| 15. expansion valve (mandatory) | | | |
| 16. expansion vessel (mandatory) | | | |
| 20. heating pump (mandatory) | | | |
| 22. radiator | | | |
| 23. pressure valve (mandatory) | | | |
| | A. cold water supply | ▴ hot water supply 3-way mixing valve from water heater | |
| | B. hot water supply | ■ outlet 3-way mixing valve to plate heat exchanger | |

Installation diagram: HeatPak with a HWH - Vented

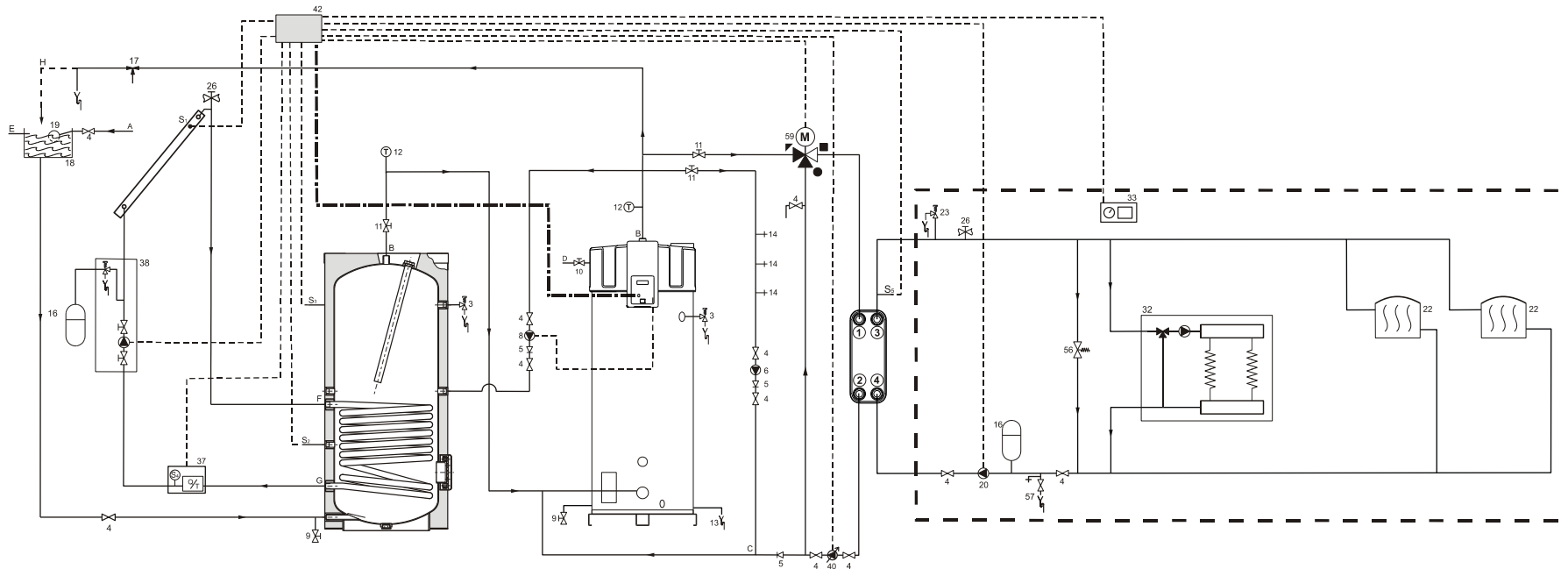

IMD-1167b R0.0

Legend

- | | | | |
|--|--|--------------------------|--|
| 3. T&P valve (mandatory) | 23. pressure valve (mandatory) | A. cold water supply | ▲ hot water supply 3-way mixing valve from water heater |
| 4. stop valve (recommended) | 26. heating filling tap (recommended) | B. hot water supply | ■ outlet 3-way mixing valve to plate heat exchanger |
| 5. non-return valve (mandatory) | 32. floor heating | C. circulation pipe | ● return water to 3-way mixing valve from plate heat exchanger |
| 6. circulation pump (optional) | 33. room thermostat | D. gas supply | |
| 9. drain valve | 40. DHW-pump | E. overflow pipe | |
| 10. manual gas valve (mandatory) | 42. control HeatPak module | F. supply heat exchanger | |
| 11. service stop valve (recommended) | 56. pressure valve (recommended) | G. heat exchanger return | |
| 12. temperature gauge (optional) | 57. filling and draining valve (mandatory) | H. overflow protection | |
| 13. condensation drain | 59. 3-way mixing valve (mandatory) | | |
| 14. draw-off point | | | |
| 18. expansion vessel (mandatory) | | | |
| 17. 3-way aeration valve (recommended) | | | |
| 18. cold water head tank | | | |
| 19. float switch | | | |
| 20. heating pump (mandatory) | | | |
| 22. radiator | | | |
-
- | |
|--|
| S ₁ collector sensor |
| S ₂ tank sensor |
| S ₃ top tank sensor |
| S ₄ solar heating system return sensor (optional) |
| S ₅ heating system sensor |

Installation diagram: HeatPak with a HWH - Unvented

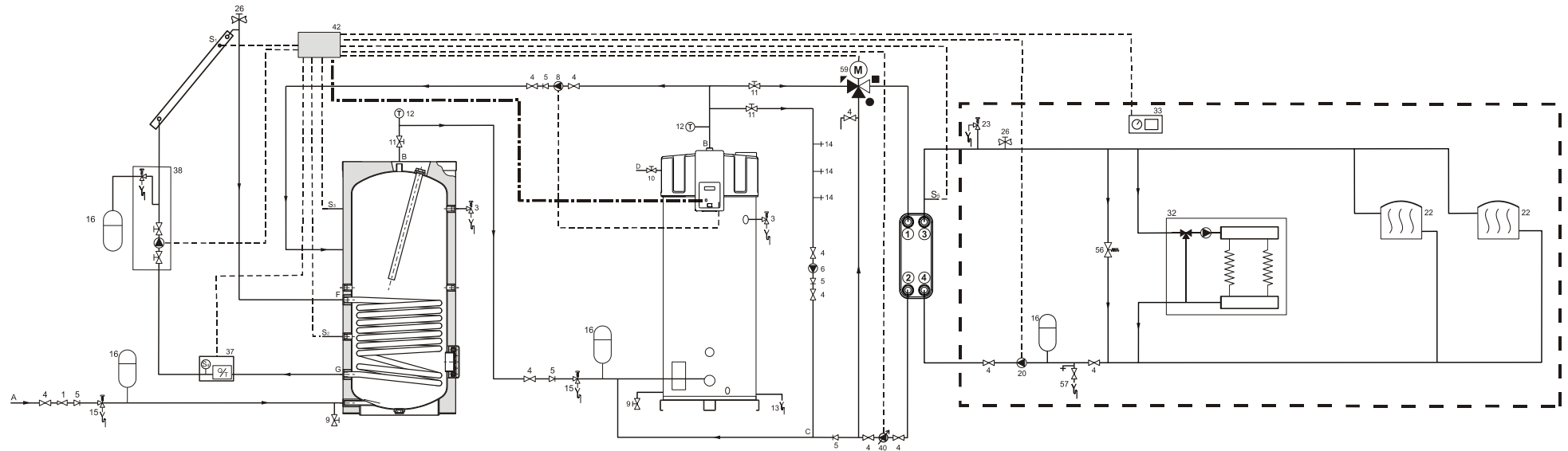

IMD-1168b R0.0

Legend

- | | | | |
|--|---|---|--|
| 1. pressure relief valve (mandatory if the mains water pressure is too high) | 32. floor heating | C. circulation pipe | ● return water to 3-way mixing valve from plate heat exchanger |
| 3. T&P valve (mandatory) | 33. room thermostat | D. gas supply | |
| 4. stop valve (recommended) | 37. combined Q/T sensor (optional) | F. supply heat exchanger | |
| 5. non-return valve (mandatory) | 38. solar heating pump station (modulating - mandatory) | G. heat exchanger return | |
| 6. circulation pump (optional) | 40. DHW-pump | | S ₁ collector sensor |
| 8. program controlled pump (mandatory) | 42. control solar heating system | | S ₂ tank sensor |
| 9. drain valve | 56. pressure valve (recommended) | | S ₃ top tank sensor |
| 10. manual gas valve (mandatory) | 57. filling and draining valve (mandatory) | | S ₄ solar heating system return sensor (optional) |
| 11. service stop valve (recommended) | 59. 3-way mixing valve (mandatory) | | S ₅ heating system sensor |
| 12. temperature gauge (optional) | | | |
| 13. condensation drain | | | |
| 14. draw-off point | | | |
| 15. expansion valve (mandatory) | | | |
| 16. expansion vessel (mandatory) | | | |
| 20. heating pump (mandatory) | | | |
| 22. radiator | | | |
| 23. pressure valve (mandatory) | | | |
| 26. heating filling tap (recommended) | | | |
| A. cold water supply | | | |
| B. hot water supply | | | |
| | | ▸ hot water supply 3-way mixing valve from water heater | |
| | | ■ outlet 3-way mixing valve to plate heat exchanger | |

3.5 Water connections

Warning

The installation should be carried out by a competent person, in compliance with general and locally applicable regulations (1.3 "Regulations").

This section covers the following topics:

- Connecting the 3-way mixing valve;
- Connecting the DHW-pump;
- Connecting the plate heat exchanger.

3.5.1 Connecting the 3-way mixing valve

See (59) in the installation diagram (3.4 "Installation diagram").

1. Fit the hot water supply pipe to the ▽-side of the 3-way mixing valve.
2. Fit the outlet of the 3-way mixing valve (■-side) on to the inlet of the plate heat exchanger ① (HeatPak side of the plate heat exchanger).
3. Fit the return pipe of the plate heat exchanger ② on the ●-side of the 3-way mixing valve.

3.5.2 Connecting the DHW pump

See (40) in the installation diagram (3.4 "Installation diagram").

1. Fit the supplied DHW-pump (40).
2. Fit two stop valves (4) for servicing.
3. Fit a non-return valve (5) after the DHW-pump to guarantee the direction of circulation.
4. Fit the cold water side, of the DHW system, to the circulation pipe and the ●-side of the 3-way mixing valve, according to the installation diagram (3.4 "Installation diagram").

3.5.3 Connecting the plate heat exchanger

Note

To guarantee the proper operation of the HeatPak module, the plate heat exchanger must be connected counter current.

Note

The length of the pipe between the water heater and the heat exchanger should not exceed 5 m, at a pipe diameter of 22 mm. When a different pipe diameter is desired, please contact Lochinvar Ltd..

See the installation diagram, (3.4 "Installation diagram").

HeatPak system/DHW-system

1. Fit the outlet of the 3-way mixing valve (■-side) to the inlet ① of the plate heat exchanger.
2. Fit the outlet of the plate heat exchanger ② to the stop valve (4) before the DHW pump.

Heating system

1. Fit the heating return pipe, of the heating system, to the inlet of the plate heat exchanger ④, according to the installation diagram (3.4 "Installation diagram").
2. Fit the heating supply pipe, of the heating system, to the outlet of the plate heat exchanger ③, according to the installation diagram (3.4 "Installation diagram").

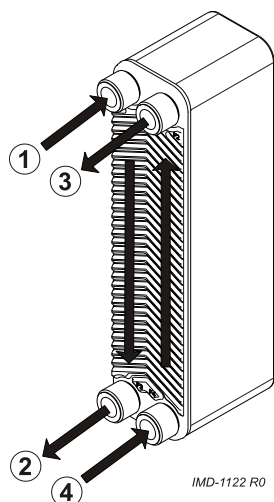

Note

The composition of the HeatPak module has influence on the selection of the required heating pump. To select the right heating pump, the table below shows the characteristics, of the heating side, that affect the choice of heating pump.

HeatPak module	P (kW)	ΔT	Specifications plate heat exchanger heating side	
			flow (m ³ /h)	ΔP (kPa)
H(P) 20 06	20	36-30	2,9	8
H(P) 20 10	20	40-30	1,7	9
H(P) 20 20	20	70-50	0,9	2,5
H(P) 30 06	30	36-30	4,3	10
H(P) 30 10	30	40-30	2,6	6,5
H(P) 30 20	30	70-50	1,3	5
H(P) 40 06	40	36-30	5,8	17
H(P) 40 10	40	40-30	3,5	11
H(P) 40 20	40	70-50	1,8	9

Note

Place, in the return pipe of the DHW-system a non-return valve (2.4.2 "Controller" and 3.4 "Installation Diagram"). Place this non-return valve between the DHW-system and the HeatPak system.

This non-return valve ensures that there will not flow cold water, beyond the DHW-system, when hot water is drawn. The non-return valve ensures that the pressure difference over the 3-way mixing valve is not too large.

Note

The non-return valve is not a part of the HeatPak module. The installer must provide this valve.

3.6 Electrical connections

Warning

The installation should be carried out by a competent person, in compliance with general and locally applicable regulations (1.3 "Regulations").

This section covers the following topics:

- Preparation;
- Connecting the mains power;
- Connecting the DHW-pump;
- Connecting the heating pump;
- Connecting the heating sensor;
- Connecting the 3-way mixing valve;
- Connecting the room thermostat;
- Connecting the communication cable.

3.6.1 Preparation

Remove the cover (snap-on type) from the terminal block of the control. The connection diagram below is under the cover.

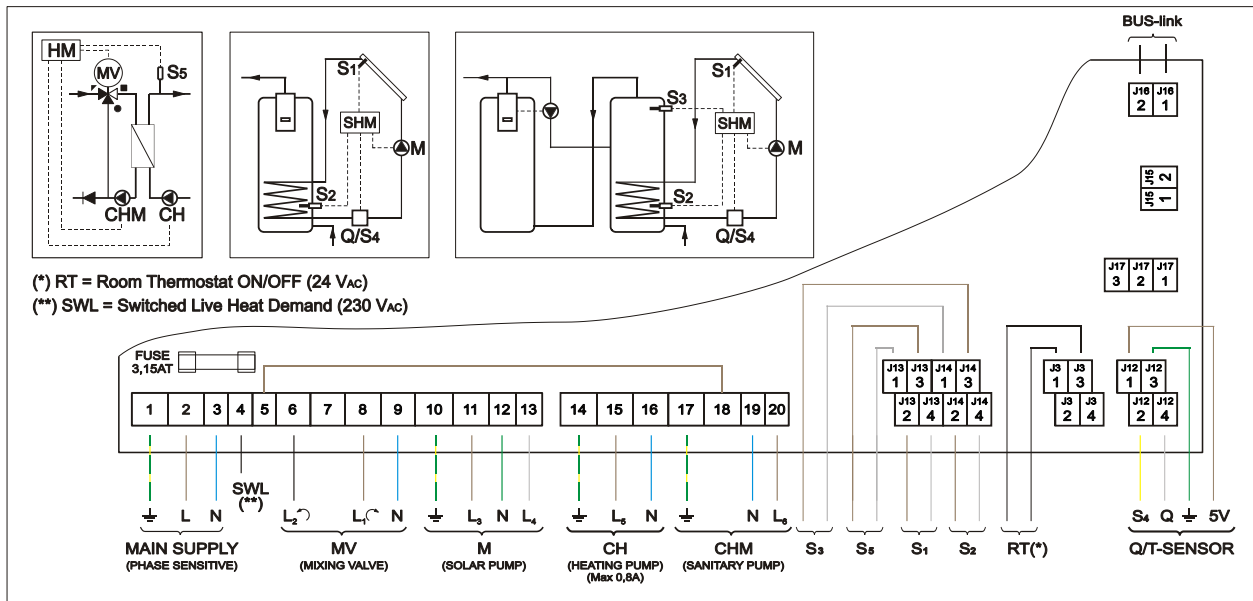

HeatPak module for ECH

Mount, using the 4 mounting holes in the housing, the controller as close as possible to the water heater on a solid and firm surface.

Note

On the cover of the controller is a label with the coding HM 2.0. When this code is not on the label present, you must contact Lochinvar Ltd.

HeatPak module for HWHC and HWH

This controller is delivered with the HWHC and HWH. The functionality of HeatPak is enclosed in the controller of the solar system.

Note

Not all solar heating controllers are equipped with HeatPak functionality. The controller that is equipped with this functionality has a label on the cover of the controller with the coding SHM 2.0. When this code is not on the label present, you must contact Lochinvar Ltd.

Note

Between terminal 5 and 18 is a brown wire mounted. This wire must remain installed at all times.

3.6.2 Connecting the mains power (only ECH)

Note

Just as with the water heater controller, the HeatPak controller must have a permanent electrical connection to the mains power supply. There must be a double-pole isolator installed in the permanent connection. This is the same double-pole isolator as installed between the mains power supply and the water heater itself. Whenever this isolator is operated, both controllers can be switched on or off.

Terminal	Type	Colour	Description
1	Earth	yellow/green	Earth control.
2	Live	brown	Live input control via isolator.
3	Neutral	blue	Neutral control.

Note

Fit cables in the strain relief.

Caution

The controller, as the controller of the water heater, is phase-sensitive. It is **absolutely essential** to connect the mains live (L) to the live of the water heater, and the mains neutral (N) to the neutral of the water heater.

Caution

There must be **no potential difference** between neutral (N) and earth (\perp). If this is the case, then an isolating transformer must be used in the supply circuit.

3.6.3 Connecting DHW pump

The HeatPak module is supplied with a DHW-pump (3-wire connection, 230 V_{AC}). You must connect this pump to the controller of the HeatPak system.

Terminal	Type	Colour	Description
17	Earth	yellow/green	Earth DHW-pump.
18	Neutral	blue	Neutral DHW-pump.
20	Live	brown	Live output of controller to DHW-pump.

Note

Fit cables in the strain relief.

3.6.4 Connecting heating pump

The heating pump (3-wire connection, max. 0,8A) is mounted in the heating system. You must connect this pump to the controller.

Terminal	Type	Colour	Description
14	Earth	yellow/green	Earth heating pump.
15	Live	brown	Live output of controller to heating pump.
16	Neutral	blue	Neutral heating pump.

Note

Fit cables in the strain relief.

Note

The composition of the HeatPak module has influence on the selection of the required heating pump. To select the right heating pump, the table below shows the characteristics, of the heating side, that affect the choice of heating pump.

HeatPak module	P (kW)	ΔT	Specifications plate heat exchanger heating side	
			flow (m ³ /h)	ΔP (kPa)
H(P) 20 06	20	36-30	2,9	8
H(P) 20 10	20	40-30	1,7	9
H(P) 20 20	20	70-50	0,9	2,5
H(P) 30 06	30	36-30	4,3	10
H(P) 30 10	30	40-30	2,6	6,5
H(P) 30 20	30	70-50	1,3	5
H(P) 40 06	40	36-30	5,8	17
H(P) 40 10	40	40-30	3,5	11
H(P) 40 20	40	70-50	1,8	9

3.6.5 Connecting heating sensor
Note

This sensor (S₅ - 12k Ω NTC) must be mounted on the heating supply pipe as close as possible to the plate heat exchanger.

Terminal	Type	Colour	Description	
J13	1	-	grey	Temperature sensor S ₅
	3	-	grey	Temperature sensor S ₅

Note

Fit cables in the strain relief.

3.6.6 Connecting 3-way mixing valve

The HeatPak module is supplied with a 3-way mixing valve (3-wire connection, 230 V_{AC}). You must connect this valve to the controller.

Terminal	Type	Colour	Description
6	Live \cup	black	Live output of controller to 3-way mixing valve (Opens hot water supply from water heater)
8	Live \cup	brown	Live output of controller to 3-way mixing valve (Opens return water supply from plate heat exchanger).
9	Neutral	bleu	Neutral 3-way mixing valve.

3.6.7 Connecting room thermostat

Note

A room thermostat must always be connected to the HeatPak system. Otherwise the HeatPak system and heating system will not function.

The room thermostat must always be an ON/OFF thermostat or an Switched Live-thermostat (SWL). An OpenTherm or other thermostat does not work in combination with the HeatPak module.

Possibility 1 : ON/OFF-thermostat

The ON/OFF-thermostat (2-wire connection, a 24 V signal is standard supplied by the HeatPak Module) is part of the heating system. You must connect this valve to the controller.

Terminal	Type	Colour	Description
J3	1	-	Room thermostat
	3	-	Room thermostat

Note

Fit cables in the strain relief.

Possibility 2 : SWL-thermostat

The SWL-thermostat (1-wire connection, a 230 V_{AC} signal is standard supplied by the HeatPak Module) is part of the heating system. You must connect this valve to the controller.

Terminal	Type	Colour	Description
4	-	-	SWL-signal of SWL-thermostat

Note

Fit cables in the strain relief.

3.6.8 Connecting communication cable (only ECH)

Note

The communication cable must always be connected, otherwise neither the water heater nor HeatPak controller will run.

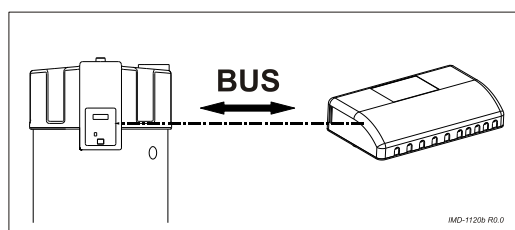

Terminal	Type	Colour	Description
J16	1	-	black BUS-link (to terminal 23 on the connection strip of the water heater)
	2	-	black BUS-link (to terminal 24 on the connection strip of the water heater)

Note

Fit cables in the strain relief.





See below or instruction manual of the water heater:

- electrical connection diagram (17.3 "Electrical diagram for the water heater")

See electrical diagram of the HeatPak module:

- electrical diagram HeatPak (ECH) (11.3 "Electrical diagram HeatPak module (ECH)")

Terminal block water heater

Mains voltage			Isolating transformer						Alarm Out			Program-controlled pump								External ON/OFF		Bus-link	
			primary			secondary																	
N	L		N	L ₁		N	L ₂		X ₁	X ₂		N	L ₃		-	-	-	-	-	X ₃	X ₄	X ₅	X ₆
1	2	3	4	5	6	7	8	9	10	11	12	13	14	15	16	17	18	19	20	21	22	23	24



If you have no mote connection to make:

- Fit the cover (snap-on type) over the controller.

4 Filling

Warning

The installation should be carried out by a competent person, in compliance with general and locally applicable regulations (1.3 "Regulations").

This chapter describes the filling activities to be carried out before final commissioning the installation.

4.1 HeatPak system

Fill the DHW-system first. Consult the Installation, Commissioning, User & Maintenance Instructions of the water heater for filling the DHW-system.

Warning

During filling the water heater and controller of the HeatPak module should be isolated from the mains power supply, this to avoid the activation of the DHW- and heating pump when there is no water in the system.

In order to fill the HeatPak side of the system proceed as follows:

1. If present, open the stop valve (4) in the DHW-system for the circulation pump (6).
2. Pull the knob, on the top of 3-way mixing valve motor, and turn it about 45° to the left (counter clockwise) until it stops.
3. Bleed the HeatPak system. If present, open the (manual) stop valve near the 3-way mixing valve.
4. The system is now under water pressure.
5. After bleeding, turn the knob 45° (clockwise) to the right to its original position and push the knob in.

4.2 Heating system

In order to fill the heating side of the system use the fill and drain valve (57) in the heating system.

Warning

During filling the water heater and the controller of the HeatPak module needs to be isolated from the main power supply, in order to prevent that the DHW-pump and the heating pump will be activated.

Note

The heating system should be filled with drinking water according to the European Drinkwater Directive 98/83/EC. If it is desired to add additives to the heating system, the heating water must meet the liquid classes 1, 2 or 3 described in the EN 1717.

5 Draining

This chapter describes the draining activities to be carried out before final decommissioning the installation.

5.1 HeatPak system

First drain the DHW-system. For draining the DHW-system, see Installation, Commissioning, User & Maintenance Instructions (6 "Draining") of the water heater.

Warning

Before draining the system the water heater and controller of the Heat Pak module, must be isolated from the mains power supply by using the double poled isolator.

In order to drain the HeatPak system is it advised to use the drain valve of the water heater. By opening the (manual) stop valve you can bleed the system.

5.2 Heating system

In order to drain the heating side of the system use the fill and drain valve (57) in the heating system.

6 Starting

6.1 Introduction

This chapter covers the following topics:

- Set heating functionality;
- Set heating set point;
- Set priority protocol.

6.2 Set heating functionality

To get the HeatPak module to function, this functionality must be activated in the control of the water heater. This functionality must be activated by the following procedure:

1. Switch on the power supply to the water heater using the isolator between the water heater and the power supply.
2. Switch on the power supply to the HeatPak module using the isolator between the control and the power supply.
3. Switch the controller, of the water heater, **ON** by setting the ON/OFF-switch to **position I**.

The display will now show INTERNAL CHECK for 10 seconds, and will then go to the main menu.

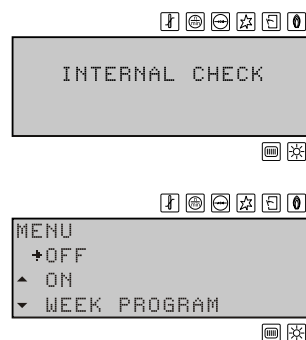

4. Press  once to bring up the service program. The display, as shown in the figure, will appear.

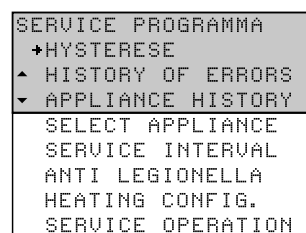

5. Press once on the blue arrow () to position the cursor beside HEATING CONFIG., the press ENTER. The display, as shown in the figure, will appear.

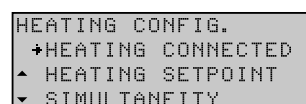

6. Confirm the selection HEATING CONNECTED with ENTER. The display, as shown in the figure, will appear.

```
HEATING CONNECTED
  YES
▲  +NO
▼
```

7. Press once on the red arrow (▲) to position the cursor beside YES, then press ENTER. By pressing ENTER the HeatPak functionality will become active and You can commission the complete system.

6.3 Set heating set point

With the feature HEATING SETPOINT it is possible to set the set point of the heating system.

Note

The heating set point is not equal to the temperature that is set on the room thermostat.

The HEATING SETPOINT is reached by pressing:

-  : HEATING CONFIG. : HEATING SETPOINT

The display, as shown in the figure, will appear.

```
HEATING SETPOINT
▲  +30°C
▼
```

Simply use the red arrow (▲) or blue arrow (▼) to set the required set point. The temperature can be set to any value between 30°C.....75°C.

Note

The heating set point depends on the type heating system (for example. High temperature heating or low temperature heating, etc.).

After setting the required temperature, this temperature can be confirmed by pressing ENTER.

6.4 Set priority protocol

With the priority protocol you can specify whether the production DHW water has or does not have priority over the heating of heating water. The default value of the priority protocol is NO. With this setting the production of DHW-water has priority over the heating of the heating water. If you have any questions please contact Lochinvar Ltd..

The priority protocol is reached by pressing:

-  : HEATING CONFIG. : SIMULTANEITY

The display, as shown in the figure, will appear.

```
SIMULTANEITY
  YES
▲  +NO
▼
```

Press once on the red arrow (▲) to position the cursor beside YES, then press ENTER. By pressing ENTER the production of DHW and hot heating water may take place simultaneously. This can effect the comfort of the DHW-system.

7 Shutting down

7.1 Introduction

This chapter covers the following topics:

- Decommissioning, the system, for a short period;
- Decommissioning, the system, for a long period.

7.2 Decommissioning for a short period

The system consists out of two parts:

1. DHW-system;
2. HeatPak system.

7.2.1 DHW-system

To decommission the DHW-system for a short period, you must activate the frost protection of the water heater. The frost protection will prevent water from freezing in the water heater.

Note



By activating the frost protection you will water from freezing in the DHW-system and HeatPak system and NOT the heating system. To prevent water freezing in the heating system is responsibility of the installation engineer of the heating system.

Important

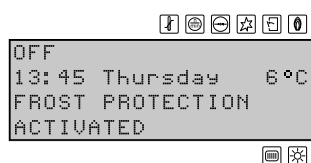
When switching on the frost protection, on the water heater, the water heater can still respond to any heat demand from the heating system. When the heating system generates heat demand the heating cycle of the water heater will start. The display of the controller is shown as in the figure.



Activate the frost protection as follows:

1. Press button  to select the main menu.
2. Using  and , place the cursor beside OFF. Confirm with ENTER.

The frost protection cuts in when the water temperature drops below 5°C. The text FROST will then appear on line one of the display. The water heater will heat the water to 20°C (T_{set}) before dropping back to mode OFF.

Note

These values of 5°C and 20°C cannot be adjusted.

7.2.2 HeatPak system

The HeatPak system can be decommissioned for a short period of time via HEATING CONFIG.. It is advised to decommission the HeatPak system for a short period of time for service.

To decommission the HeatPak module for a short period of time via HEATING SETTINGS the following steps must be made

1. Press  once to reach the service program. The display, as shown in the figure, will appear.

```
SERVICE PROGRAMMA
+HYSTERESE
^ HISTORY OF ERRORS
v APPLIANCE HISTORY
SELECT APPLIANCE
SERVICE INTERVAL
ANTI LEGIONELLA
HEATING CONFIG.
SERVICE OPERATION
```

2. Press once on the blue arrow () to position the cursor beside HEATING CONFIG. and press ENTER. The display, as shown in the figure, will appear.

```
HEATING CONFIG.
+HEATING CONNECTED
^ HEATING SETPOINT
v SIMULTANEITY
```

3. Confirm the selection HEATING CONNECTED with ENTER. The display, as shown in the figure, will appear.

```
HEATING SYSTEM
+YES
^ NO
v
```

4. Press on the blue arrow () to position the cursor beside NO and press ENTER. By pressing enter the HeatPak functionality has been turned off. It is now possible to turn off the system.

Important

By turning of the HeatPak module this way you also turn off the heating system. Any heat demand from the room thermostat can not be answered. The DHW-system continues to operate. The pump protection also remains active.

7.3 Decommissioning for a long period

The system consists out of two parts:

1. DHW-system;
2. HeatPak system.

7.3.1 DHW-system

To decommission the DHW-system for a longer period it is recommend to drain the system. For draining the DHW-system, see Installation, Commissioning, User & Maintenance Instructions (6 "Draining") of the water heater.

7.3.2 HeatPak system

Isolate the controller, of the HeatPak module, from the power supply by setting the isolator between the controller and the mains power supply to position 0.

8 Errors

8.1 Introduction

A distinction is made between errors caused by the water heater and errors caused by the HeatPak module. Errors caused by the water heater can be found in the Installation-, User- and Service manual of the water heater. In this manual you will find errors caused by the HeatPak module.

A distinction is made between:

- **General errors**

General errors are not reported on the display, of the water heater.

The Installation, Commissioning, User & Maintenance Instructions, of the water heater, includes a table with general errors ([13.2 "Troubleshooting table for general errors"](#)) related to the water heater.

This Installation, Commissioning, User & Maintenance Instructions includes a table with general errors ([8.2 "Troubleshooting table for general errors"](#)) related to the HeatPak module.

- **Displayed errors**

Errors are reported on the display of the water heater as follows:

- Line one: an error code and a brief description. The code consists of a letter and two digits.
- Line two, three and four: a long description, alternating with a recommended action. See the figures. The first shows a possible error, the second shows the appropriate checking action.

```
F20: T_HEATING HIGH
      CENTRAL HEATING
      TEMPERATURE
      TOO HIGH
```

```
F20: T_HEATING HIGH
      CHECK
      PUMP & VALVE
      CENTRAL HEATING
```

There are various types of errors, all falling into one of two groups:

- **LOCK OUT ERRORS**
When the cause has been removed, these errors require a rest with the RESET button, before the HeatPak module can resume operation
- **BLOCKING ERRORS**
These errors disappear automatically once the cause of the error has been removed, after which the HeatPak module resumes operation by itself.

The Installation, Commissioning, User & Maintenance Instructions of the water heater includes a table of error messages ([13.3 "Troubleshooting table for displayed errors"](#)) that can appear on the display, related to the water heater.

This manual includes a table of error messages ([8.3 "Troubleshooting table for displayed errors"](#)) that can appear on the display of the water heater, related to the HeatPak module.

8.2 Troubleshooting table for general errors

Indication	Cause	Measure	Remark
Water leakage	Leakage from water connection (threaded).	Tighten the threaded connection.	If the leak persists, consult your installation engineer.
	Leakage from another nearby water heater or pipe segment.	Trace the leak.	
	Leakage from HeatPak module parts.	Trace the leak. If leakage can not be solved replace leaking part or consult the supplier and/or manufacturer.	
Heating system stays cold (1/2)	The water heater is off.	Start the water heater (see Installation, Commissioning, User & Maintenance Instructions of the water heater, 9 " <u>Starting the water heater</u> ")	<ul style="list-style-type: none"> - See electrical diagram (11 "Appendices"). - If the error persists, consult you installation engineer.
	No supply voltage present on the water heater and controller of the HeatPak module.	<ol style="list-style-type: none"> 1. Check whether the isolator is ON. 2. Check that there is power to the isolator. 3. Check whether the ON/OFF-switch of the controller, of the water heater, is ON (position I) 4. Check whether there is power to the electrical connector block of the water heater. 5. The measured voltage must be 230 V_{AC} (-15%, +10%). 	
	Heating functionality has not been activated.	Activate the heating functionality (6.2 " <u>Heating functionality</u> ").	If there continues to be insufficient or no hot water, consult your installation engineer.
	Room thermostat is not connected or is not functioning.	<ol style="list-style-type: none"> 1. Check whether the room thermostat is connected correctly (electrical). 2. Check whether the cable (from controller to thermostat) is connected (electrical) to the room thermostat. 	
		Check whether the room thermostat is functioning.	
	Hot water supply is used up.	Reduce hot water consumption and give the water heater time to heat up.	
	Heating setpoint is set to low.	Set the heating setpoint to a higher setting (6.3 " <u>Setting heating setpoint</u> ").	
	Priority protocol is active.	Check whether the priority protocol (production of DHW-water has priority over the production of heating water) is active.	

Table continues on next page.

Indication	Cause	Measure	Remark
Heating system stays cold (2/2)	Pump from heating system is not functioning.	Check whether the (heating) pump is correctly connected.	If there continues to be insufficient or no hot water, consult your installation engineer.
		Check whether there is power on the (heating) pump connections on the controller of the HeatPak module. The measured voltage must be 230 V _{AC} (-15%, +10%)	
		Check the (hydraulic) operation of the (heating) pump: 1. Bleed the pump, when air is present. 2. Unblock the pump or replace the pump in case of seizing.	
	Pump from DHW-system is not functioning.	Check whether the (DHW) pump is correctly connected.	
		Check whether there is power on the (DHW) pump connections on the controller of the HeatPak module. The measured voltage must be 230 V _{AC} (-15%, +10%)	
		Check the (hydraulic) operation of the (DHW) pump: 1. Bleed the pump, when air is present. 2. Unblock the pump or replace the pump in case of seizing.	
	3-way mixing valve is not functioning.	Check whether the 3-way mixing valve is connected (electrical).	
		Check whether there is power on the (3-way mixing valve) connections on the controller of the HeatPak module. The measured voltage must be 230 V _{AC} (-15%, +10%)	
		Check whether the 3-way mixing valve is correctly (hydraulically) connected.	
		Check whether the 3-way mixing valve is correctly configured (1.5 "Configuration 3-way mixing valve").	

8.3 Troubleshooting table for displayed errors

Indication	Cause	Measure	Remark
C05 (blocking error) Error message from the HeatPak controller.	<ul style="list-style-type: none"> Incorrect reference voltage from the AD-converter. EEPROM error 	<ol style="list-style-type: none"> Reset controller. Check that the frequency of the power supply is compliant with 50 Hz ± 1 Hz. If not, contact your installation engineer If the frequency is correct but the error persists, replace the controller. 	<ul style="list-style-type: none"> If the error persists, consult you installation engineer. To replace the necessary parts, you must contact your installation engineer.
F18 (blocking error) Communication error.	No supply voltage present on HeatPak control.	Check whether there is power to the controller. The measured voltage must be 230 V _{AC} (-15%, +10%).	<ul style="list-style-type: none"> See electrical diagram (see Installation, Commissioning, User & Maintenance Instructions of the water heater, <u>17 "Appendices"</u> or <u>11 "Appendices"</u> of this manual). If the error persists, consult you installation engineer. To replace the necessary parts, you must contact your installation engineer.
	No communication cable (correctly) connected or damaged.	<ol style="list-style-type: none"> Check whether there is a (communication) cable between the controller of the water heater and the controller of the HeatPak module/solar heating system. In case of no cable, a (communication) cable must be connected. In case of damage, the (communication) cable must be replaced. 	
	Short circuit Q/T-sensor.	<p>Check whether the Q/T-sensor is connected correctly to the controller.</p> <ol style="list-style-type: none"> Disconnect the Q/T-sensor. In case of no cable, a cable must be connected. In case of damage, the cable must be replaced. 	
F20 (blocking error) (1/2) Temperature of heating system is to high.	DHW-pump not functioning.	<ol style="list-style-type: none"> Check whether the (DHW) pump is correctly (electrical) connected to the controller. Check whether the (DHW) pump is correctly connected hydraulically. 	<ul style="list-style-type: none"> See electrical diagram (<u>11 "Appendices"</u>). To replace the necessary parts, you must contact your installation engineer.
	Heating pump not functioning.	<ol style="list-style-type: none"> Check whether the (heating) pump is correctly (electrical) connected to the controller. Check whether the (heating) pump is correctly connected hydraulically. 	

Table continues on next page.

Indication	Cause	Measure	Remark
F20 (blocking error) (2/2) Temperature of heating system is to high.	3-way mixing valve not functioning.	1. Check whether the 3-way mixing valve is connected correctly. 2. Check whether the cable of the 3-way mixing valve (correctly) connected to the controller. 3. Check whether the 3-way mixing valve is correctly configured (11.5 "Configuration 3-way mixing valve").	<ul style="list-style-type: none"> - See electrical diagram (11 "Appendices"). - To replace the necessary parts, you must contact your installation engineer.
	Sensor S ₅ not correctly positioned.	Check whether the sensor is correctly positioned in the heating system.	
	Sensor S ₅ not (correctly) connected.	Check whether the sensor is connected correctly	
S10 (blocking error) Open circuit of sensor S ₅ .	Sensor S ₅ not (correctly) connected.	Connect sensor S ₅ correctly.	<ul style="list-style-type: none"> - See electrical diagram (11 "Appendices"). - To replace the necessary parts, you must contact your installation engineer.
	Damaged cable and/or defective sensor	Replace cable and/or sensor.	
S20 (blocking error) Short circuit of sensor S ₅ .	Short circuit of sensor circuit.	Replace cable and/or sensor.	<ul style="list-style-type: none"> - To replace the necessary parts, you must contact your installation engineer.

9 Performing maintenance

Caution

Maintenance may only be carried out by an approved service and maintenance engineer.

At each service, the HeatPak system must have a complete visual inspection and mainly consists of detecting leakage. The maintenance should be carried out to the following components:

- DHW-pump;
- Heating pump;
- 3-way mixing valve;
- Temperature sensor S₅;
- Plate heat exchanger;

10 Warranty

10.1 General warranty

Our warranty is to provide a replacement component in exchange for the return of the defective component and is subject to an audit upon receipt of the faulty component. Replacement components must be paid for in full prior to dispatch unless we agree otherwise. The warranty does not include any labour costs or carriage of the returned component.

If (after verification and at the sole discretion of Lochinvar Limited) a component or part of the HeatPak module supplied by Lochinvar Limited proves, within one year from the date of delivery of the original appliance (unless the equipment is commissioned by Lochinvar, in which case the warranty period will begin from the completion date of the initial commissioning) to be defective or fails to function correctly due to manufacturing and/or material defects, then Lochinvar Limited shall repair or replace this component or part.

10.2 Conditions for installation and use

The warranty set out in article 1 will apply solely under the following conditions:

- a. the warranty is subject to the HeatPak being installed and maintained in accordance with the relevant Installation Commissioning and Maintenance Instructions and does not cover failures due to deliberate misuse, malicious damage, neglect, unauthorised alterations or repairs, accidental damage or third party damage.
- b. the HeatPak module remains installed at the original site of installation.
- c. the module is used exclusively with drinking water, which at all times can freely circulate (a separately installed heat exchanger is mandatory for heating saline water or corrosive water).
- d. the water temperatures in the heater do not exceed the maximum setting of the thermostats, which form a part of the water heater.
- e. the water pressure and/or heat load do not exceed the maximum values stated on the water heater rating plate.
- f. the HeatPak module is installed in a non-corrosive atmosphere or environment.
- g. the installation is connected to a protected cold water supply arrangement which is approved by the relevant Water Supplier with sufficient capacity for this purpose; supplying a pressure no greater than the working pressure stated on the water heater; and where applicable by a likewise approved temperature and pressure relief valve fitted in accordance with the relevant Installation Commissioning and Maintenance Instructions, and further in compliance with Government and local authority installation and Building Regulations.
- h. the heating installation must be fitted with temperature and pressure protection in compliance with Government and local authority installation and Building Regulations.

10.3 Exclusions

The warranty set out in article 1 will not apply in the event of:

- a. damage to the HeatPak module caused by an external factor;
- b. misuse, neglect (including frost damage), modification, incorrect and/or unauthorised use of the HeatPak module and any attempt to repair leaks;
- c. contaminants or other substances having been allowed to enter the HeatPak module;
- d. unfiltered, recirculated water flowing through (or being stored in) the HeatPak module;
- e. any attempts at repair to a defective HeatPak module other than by an approved service technician;
- f. if the heating installation is not filled with drinking water as prescribed in the European Council Directive 98/83/EG on the quality of water intended for human consumption and when additives are not compliant with the liquid class 1, 2 or 3 as described in EN 1717.

10.4 Scope of the warranty

The obligations of Lochinvar Limited by virtue of the warranty provided do not extend beyond delivery free of charge from the warehouse of the parts or components of the HeatPak module to be replaced; transport, labour, installation and other costs associated with the replacement shall not be borne by Lochinvar Limited.

10.5 Claims

If a claim is to be made under the terms of our warranty, the original purchaser of the appliance should place a purchase order for the required component and obtain a Sales Return Order (SRO) number for the return of the defective component.

To process any warranty claim, we require the following information:

- **Appliance model number**
- **Appliance serial number**
- **Date and proof of purchase**
- **Brief description of fault**

Upon receipt of the defective component, it will be tested and if the component is found to be faulty, a credit will be raised against the relevant invoice.

The warranty period starts from the date of delivery of the original appliance unless the equipment is commissioned by Lochinvar, in which case the warranty period will begin from the completion date of the initial commissioning. The warranty is held by the company/organisation that has placed the purchase order with us and is only valid if the appliance supplied has been paid for in full.

10.6 Obligations of Lochinvar Limited

Lochinvar's total liability is limited to the value of the warranted appliance or component and it shall not be responsible for any loss of income, profits (actual or anticipated), contracts or for any other business related loss, indirect or consequential losses arising in connection with the warranted appliance or component.

We retain the exclusive right to replace the product or offer a refund at our sole discretion. Such remedy shall be your sole and exclusive remedy for any breach of warranty.

Lochinvar's standard terms and conditions apply to this warranty and in the event of any inconsistency between the two, the wording in this warranty shall prevail.

11 Appendices

11.1 Introduction

This appendix contains:

- Electrical diagram of HeatPak-module for ECH ([11.2 "Electrical diagram HeatPak module \(ECH\)"](#));
- Electrical diagram of HeatPak-module for HWHC ([11.2 "Electrical diagram HeatPak module \(HWHC\)"](#));
- Electrical diagram of HeatPak-module for HWH ([11.2 "Electrical diagram HeatPak module \(HWH\)"](#));
- Configuration 3-way mixing valve ([11.5 "Configuration 3-way mixing valve"](#)).

11.2 Electrical diagram
HeatPak module
(ECH)

Electrical diagram

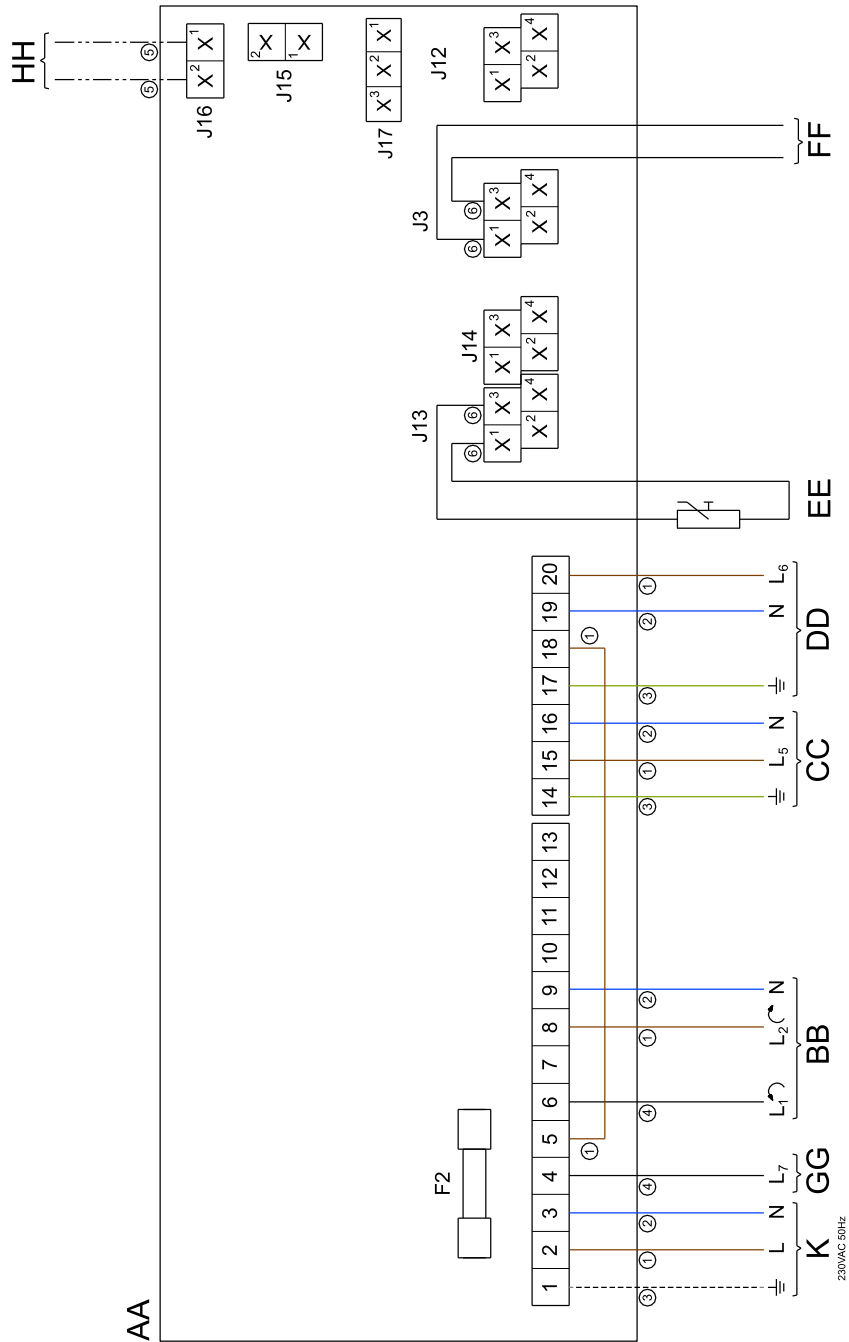

0311050 R1.0

1 = brown, 2 = blue, 3 = yellow / green, 4 = black, 5 = white, 6 = gray / beige, 7 = green, 8 = yellow

TERMINAL STRIP CONNECTIONS:

\perp	Earth
N	Neutral
L	Live input of controller
L ₁ ⊔	Live input for 3-way mixing valve (hot water supply of water heater)
L ₂ ⊔	Live input for 3-way mixing valve (return water of plate heat exchanger)
L ₅	Live input for heating pump
L ₆	Live input for DHW pump
L ₇	Live output of Switched Live room thermostat

COMPONENTENS:

AA	Controller of HeatPak system (HM 2.0)
BB	3-way mixing valve (230 V _{AC})
CC	Heating pump (230 V _{AC} , 0,8A)
DD	DHW pump (230 V _{AC})
EE	Temperature sensor (S ₅ - heating system) (12 kΩ NTC)
FF	Room thermostat (24 V _{AC} - ON/OFF)
GG	Room thermostat (230 V _{AC} - Switched Live)
HH	Communication between the water heater controller and the solar heating system controller
K	Double-pole isolator

CONTROLLER CONNECTIONS:

J3	Connection of room thermostat (ON/OFF)
J13	Connection of temperature sensor S ₅ (1-3)
J16	Connection of BUS-link communication
F2	Fuse (T 3,15 A - 250 V)

11.3 Electrical diagram
HeatPak Module
(HWHC)

Electrical diagram

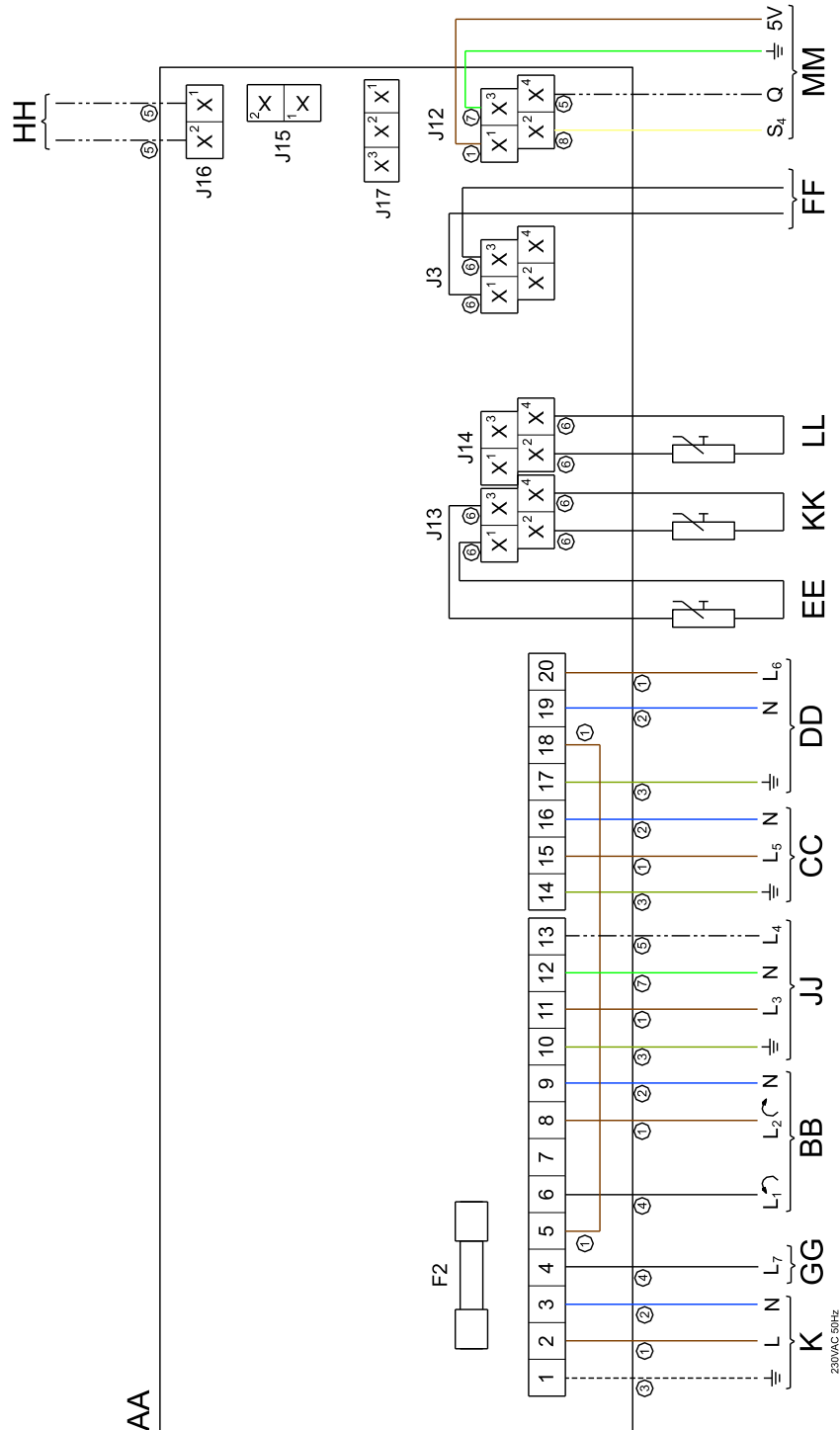

0311051 R1.0

1 = brown, 2 = blue, 3 = yellow / green, 4 = black, 5 = white, 6 = gray / beige, 7 = green, 8 = yellow

TERMINAL STRIP CONNECTIONS:

\perp	Earth
N	Neutral
L	Live input of controller
L ₁ ⊔	Live input for 3-way mixing valve (warm water supply of water heater)
L ₂ ⊔	Live input for 3-way mixing valve (return water of plate heat exchanger)
L ₃	Live input for solar heating system modulating pump
L ₄	Modulation output of the solar heating system modulating pump
L ₅	Live input for heating pump
L ₆	Live input for DHW pump
L ₇	Live output of Switched Live room thermostat

COMPONENTS:

AA	Controller of solar heating system (SHM 2.0)
BB	3-way mixing valve (230 V _{AC})
CC	Heating pump (230 V _{AC})
DD	DHW pump (230 V _{AC})
EE	Temperature sensor (S ₅ - heating system)
FF	Room thermostat (24 V _{AC} - ON/OFF)
GG	Room thermostat (230 V _{AC} - Switched Live)
HH	Communication between the water heater controller and the solar heating system controller
JJ	Solar heating system pump (modulating) (230 V _{AC})
KK	Temperature sensor (S ₁ -solar collector) (20 kΩ NTC)
LL	Temperature sensor (S ₂ - tank) (12 kΩ NTC)
MM	Combined Q/T sensor incl. temperature sensor (S ₄ - solar collector return) (12 kΩ NTC)
K	Double-pole isolator

CONTROLLER CONNECTIONS:

J3	Connection of room thermostat (ON/OFF)
J12	Connection combined Q/T sensor (1-2-3-4)
J13	Connection of temperature sensor S ₅ (1-3) and temperature sensor S ₁ (2-4)
J14	Connection of temperature sensor S ₂ (2-4)
J16	Connection of BUS-link communication
F2	Fuse (T 3,15 A - 250 V)

11.4 Electrical diagram
HeatPak Module
(HWH)

Electrical diagram

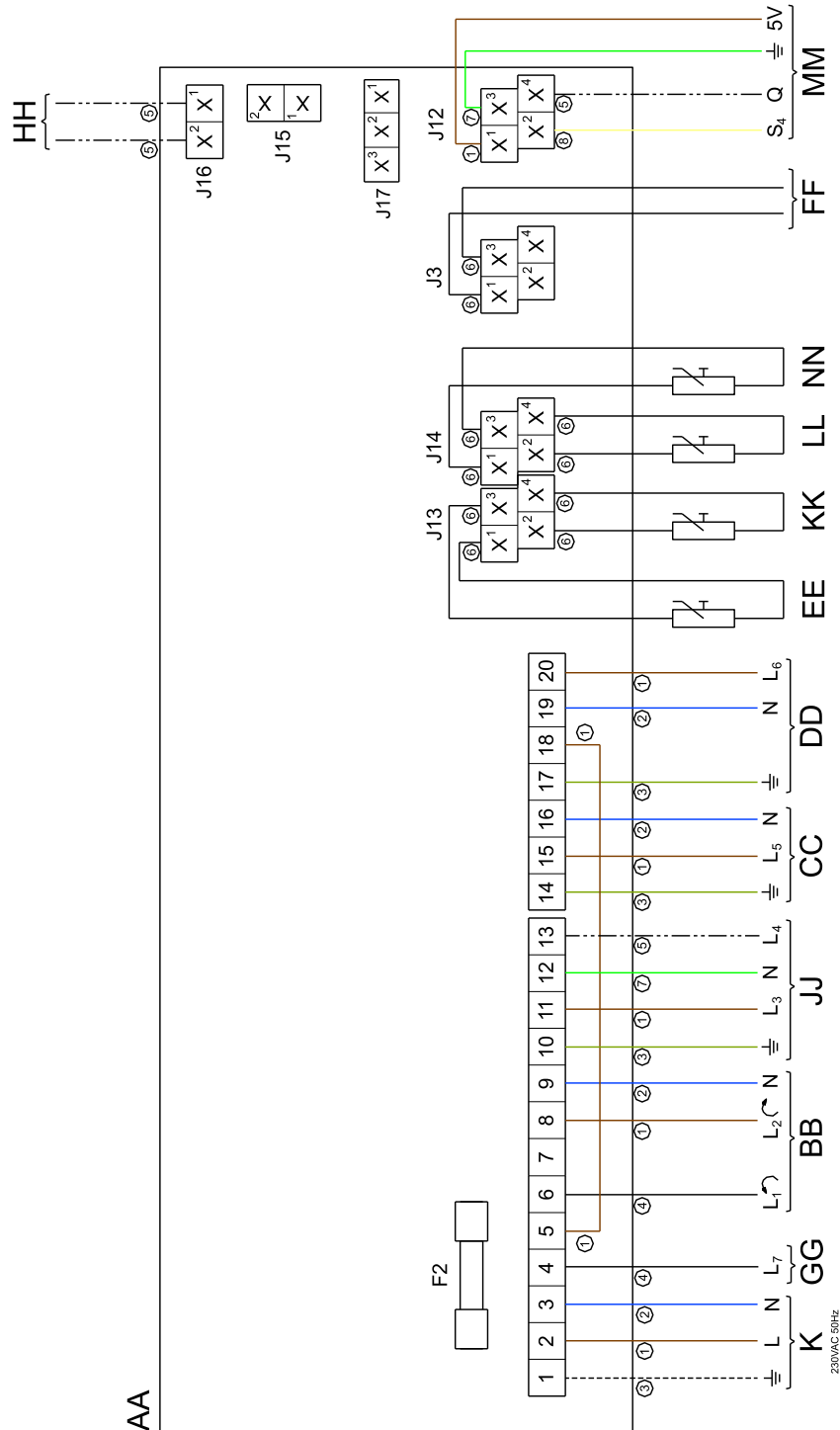

0311052 R1.0

1 = brown, 2 = blue, 3 = yellow / green, 4 = black, 5 = white, 6 = gray / beige, 7 = green, 8 = yellow

TERMINAL STRIP CONNECTIONS:

\perp	Earth
N	Neutral
L	Live input of controller
L ₁ ⊔	Live input for 3-way mixing valve (warm water supply of water heater)
L ₂ ⊔	Live input for 3-way mixing valve (return water of plate heat exchanger)
L ₃	Live input for solar heating system modulating pump
L ₄	Modulation output of the solar heating system modulating pump
L ₅	Live input for heating pump
L ₆	Live input for DHW pump
L ₇	Live output of Switched Live room thermostat

COMPONENTS:

AA	Controller of solar heating system (SHM 2.0)
BB	3-way mixing valve (230 V _{AC})
CC	Heating pump (230 V _{AC})
DD	DHW pump (230 V _{AC})
EE	Temperature sensor (S ₅ - heating system)
FF	Room thermostat (24 V _{AC} - ON/OFF)
GG	Room thermostat (230 V _{AC} - Switched Live)
HH	Communication between the water heater controller and the solar heating system controller
JJ	Solar heating system pump (modulating) (230 V _{AC})
KK	Temperature sensor (S ₁ -solar collector) (20 kΩ NTC)
LL	Temperature sensor (S ₂ - tank) (12 kΩ NTC)
MM	Combined Q/T sensor incl. temperature sensor (S ₄ - solar collector return) (12 kΩ NTC)
NN	Temperature sensor (S ₃ - top of storage tank) (12 kΩ NTC)
K	Double-pole isolator

CONTROLLER CONNECTIONS:

J3	Connection of room thermostat (ON/OFF)
J12	Connection combined Q/T sensor (1-2-3-4)
J13	Connection of temperature sensor S ₅ (1-3) and temperature sensor S ₁ (2-4)
J14	Connection of temperature sensor S ₂ (2-4) and temperature sensor S ₃ (1-3)
J16	Connection of BUS-link communication
F2	Fuse (T 3,15 A - 250 V)

11.5 Configuration 3-way mixing valve

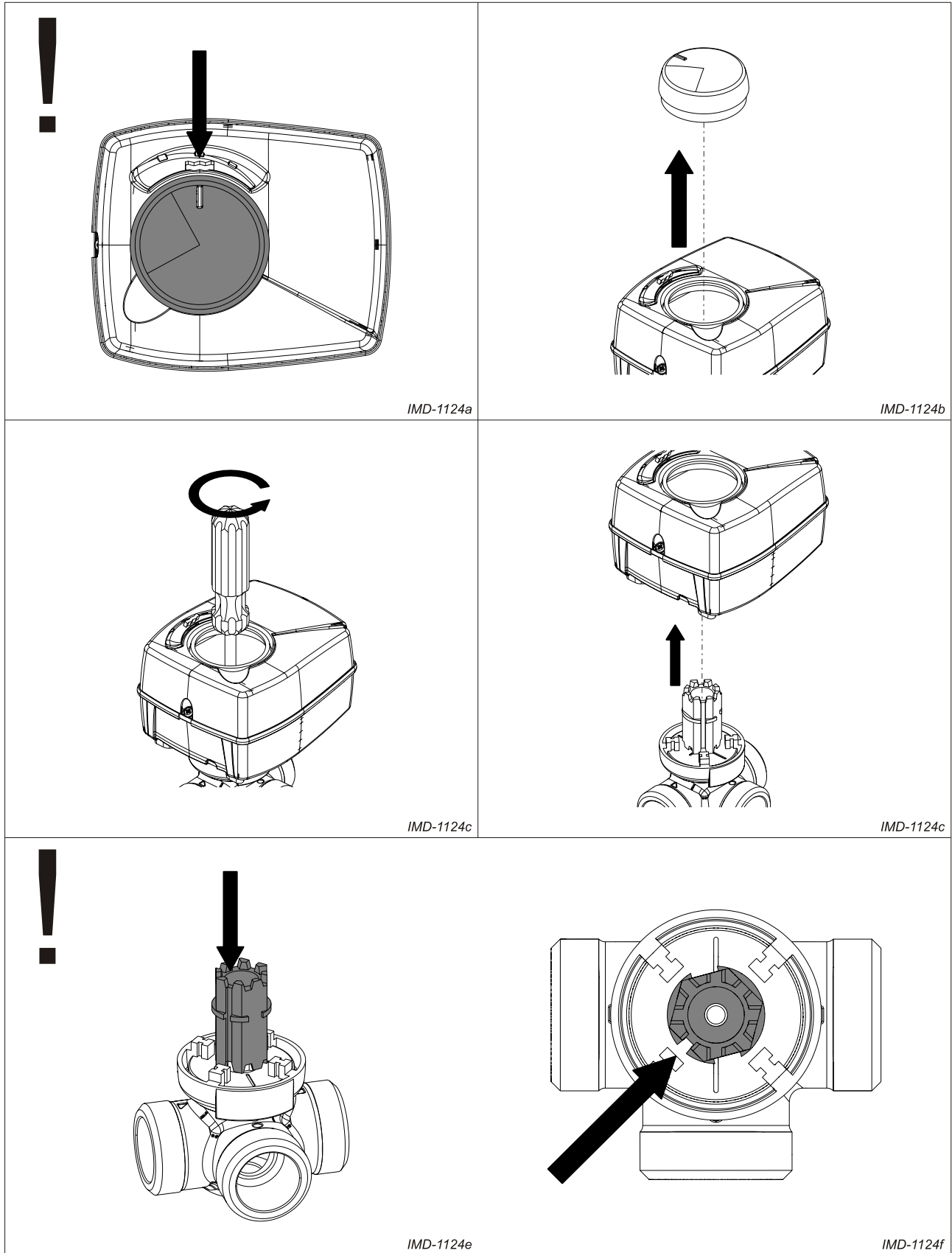

IMD-1124a

IMD-1124b

IMD-1124c

IMD-1124c

IMD-1124e

IMD-1124f

IMD-1124 R0.0

